

ARTICLE 501 OFF-STREET PARKING AND LOADING

SEC. 501.1 APPLICABILITY

- A. Zoning Districts.** These requirements for adequate off-street parking, and loading shall be provided in all zoning districts. Such parking and loading shall be provided off the street easement for each use of land within the City and as demand is created for each use.
- B. New construction, expansion, new use.** With construction or expansion in capacity of a building or structure or if another use is established on the lot, off-street parking must be provided in accordance with Article 501 of the Zoning Ordinance.
- C. Existing spaces.** Parking spaces used in connection with an existing or continuing use or building on the effective date of this ordinance, up to the number required by this ordinance shall be continued and may not be counted as serving a new structure or addition.

Parking Dimensions			
	Width (ft.)	Depth (ft.)	Maneuvering Area (ft.)
Parallel	9	22	11
30° Angle	18	17.3	11
45° Angle	12.7	19.8	13
60° Angle	10.4	21	18
90° Angle or Right Angle	9	19	24

SEC. 501.2 PARKING DIMENSIONS

- A. Standard parking space size.** The size of an off-street parking space for one vehicle shall be rectangular with dimensions of not less than nine (9) feet by eighteen (18) feet. Such measurement is exclusive of access drives or aisles.
- B. Access drive width.** If the off-street parking space does not abut on a street, alley or easement of access, there shall be provided an access drive of at least ten (10) feet in width in the case of a dwelling and at least fifteen (15) feet in width in all other cases leading from the street to the parking.
- C. Standards.** Where different parking angles are utilized for off-street parking, the following widths, depths and maneuvering areas shall be followed:

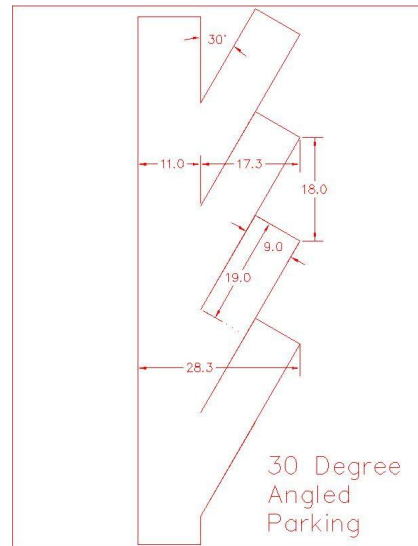

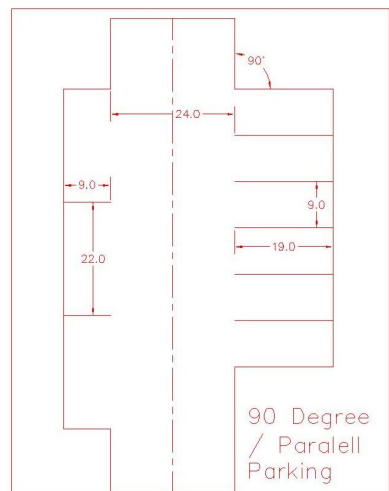
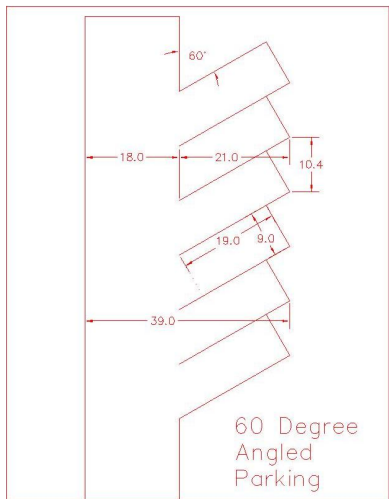
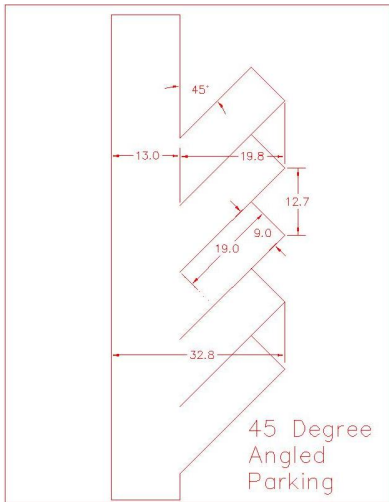

SEC. 501.3 LOCATION OF OFF-STREET PARKING

- A. Maximum Distance.** Off-street parking shall be located within two hundred (200) feet of the structure to be served except in the C-3 District, and shall have direct access to a street or alley. Distance to any parking area for the purposes of this ordinance shall be measured between the nearest point of the off-street parking space and the nearest point of the building or facility to be served by the parking. No more than 50% of parking requirements can be met off-site.
- B. Satellite Lots.** If detached parking facilities or satellite parking lots are to be provided, such lots must be located on property zoned to allow for parking.

SEC. 501.4 OWNERSHIP

The ownership of land upon which off-street parking is provided shall be the same as the ownership of land on which the principal use is located except in C-3 District or in districts for multi-family housing, rooming houses, dormitories, fraternities, and sororities where the sponsoring church or institution of higher learning has consented by written agreement to the use of its excess off-street parking for said purpose. A conditional use permit is required for the parking on lot(s) not of the same ownership to count toward fulfillment of the parking requirements.

SEC. 501.5 ACCESSIBILITY

- A. ADA Requirements.** Accessibility for persons with disabilities in parking lots and building approaches shall be as required by the current ADA and as may from time to time be amended.
- B. Accessible spaces required.** The following table shall be used to determine the minimum number of accessible parking spaces to be provided for persons with disabilities.

Accessible Spaces Required	
Total Parking Spaces	Minimum Number of Accessible Spaces Required
1-25	1
26-50	2
51-75	3
76-100	4
101-150	5
151-200	6
201-300	7
301-400	8
401-500	9
501-1000	2% of all spaces
Over 1,000	20 spaces plus 1 space for each 100 spaces over 1000

SEC. 501.6 NUMBER OF OFF-STREET PARKING SPACES REQUIRED

- A. Floor and Lot Area Defined.** For the purposes of applying requirements for off-street parking, floor area shall be defined as net floor area with the outside dimensions of a building, excluding halls, lobbies, and stairways, etc. The definition shall not include floor space within the building reserved for parking or loading of vehicles, and basement space or separate space used only for building maintenance and utilities.
- B. Uses Not Listed.** For all uses not covered in the standards below, the Planning Commission shall make a determination of the parking demand to be created by the proposed use, and the amount of parking then determined shall be the off-street parking requirement for the permitted use.
- C. Waivers.** The Planning Commission may grant waivers on the parking standards of this section.
- D. Downtown Zoning Districts (C-3, DC, and DE districts)**
- 1. New Structures.** New structures and additions shall meet the parking requirements based on the proposed use. The parking requirements in the C-3 district for new structures and additions may be reduced by 30%. The parking space requirements for the DC, Downtown Core and DE, Downtown Edge Districts are defined in Article 401.8-B.
 - 2. Existing Structures.** The parking requirements of this section and Article 401.8-B shall not apply to existing structures in the C-3, DC or DE districts with a change of use.
 - 3. Razed Structures.** The parking requirements for the C-3, DC and DE districts shall be calculated based on the square footage of the new structure minus the amount of the square footage of the building footprint of the original structure.

E. R-C2, Central Residential – Moderate Density and R-C3, Central Residential High Density Districts. (Ord. No. 2006-33, 2-28-06)

1. Standards:

- (a) One (1) parking space per dwelling unit shall be provided for multi-family development. This may be achieved via on-site parking, on-street parking or a shared parking agreement.
- (b) In a mixed-use project, parking shall be clearly marked for residents to distinguish it from employee or customer parking.
- (c) Surface parking shall be located at the side or the rear of the building to ensure that entering and exiting vehicles do not interrupt pedestrian movement at the front of the building.
- (d) Alleys shall remain clear and passable at all times.

2. Guidelines:

- (a) Shared parking access and facilities are encouraged where practical. Joint use of required parking spaces may occur where two or more establishments on the same site or on separate sites are able to share the same parking spaces because their parking demands occur at different times. In order to utilize shared parking to meet parking standards, an agreement should be submitted as part of the City's site development review process.
- (b) Structured parking should be located underground or be designed to resemble a street level building.
- (c) Access to parking via rear driveways and alleys is appropriate where possible.

F. Standards. Off-street parking shall be provided in accordance with the following schedule:

Art. 501 Off-Street Parking and Loading

Number of Parking Spaces Required	
Land Use	Parking ratio
RESIDENTIAL	
Single-Family Dwelling	2 spaces per dwelling unit
Patio Home Dwelling	2 spaces per dwelling unit
Two-Family Dwelling , Duplex	2 spaces per dwelling unit
Multi-Family Dwelling	3 spaces for each two dwelling units
Multi-Family Dwelling, Downtown Redevelopment District	1 space per dwelling unit
Hotels and Motels	1 space is required per guest room. For developments larger than twenty (20) rooms, eleven parking spaces must be provided for each ten rooms or fraction thereof for employees and non-guest users patronizing meeting rooms, and other facilities, but not including restaurants.
Manufactured Home Subdivision	2 spaces per manufactured home
Bed and Breakfast	1 space per sleeping/rental unit plus 1 space for the owner
OFFICE AND INSTITUTIONAL USES	
Hospitals, Sanitariums, Convalescent Homes (and similar uses or establishments)	1 space for each bed
Medical Clinics	1 space per 300 sq. ft. of net floor space
Auditoriums, Arenas, Theatres (and similar places of public assembly)	1 space for each four (4) seats
Church Sanctuary	1 parking space for each four (4) seats based on maximum seating capacity in the principal assembly room; provided, however, that churches may establish joint parking facilities for not to exceed fifty percent (50%) of the required spaces, with businesses, institutions and agencies that do not have a time conflict in parking demand.
Lodge halls, Exhibition halls, Clubs (and similar places of public assembly)	1 space per 200 sq. ft. of net floor area
Fire Stations	1 space per 400 sq. ft. of net floor area (Ord. No. 2004-63, 3-23-04)
Schools and Institutions	
Nursery, Kindergarten and Day-Care Centers	1 space per 500 sq. ft. of net floor area and one (1) space per employee. Loading and unloading spaces shall be required at a rate of one (1) for each ten (10) children accommodated
Elementary (grades 1-6)	1 space per classroom. Stacking space for drop-off and pick-up shall be required on the site.
Junior High School (grades 7-9)	4 spaces per classroom, stacking spaces for buses and automobiles shall be required on-site.
Senior High School (grades 10-12)	On-site parking spaces shall be provided based on total school enrollment of 1 space for every five (5) full-time students plus 1.5 spaces per classroom.
College, University, Business College or Trade School	1 space for each 300 sq. ft. of net floor area, or 1 space per four (4) students, whichever is greater
Business and Professional Office (and similar use or establishment)	1 space per 300 sq. ft. of net floor area. For structures larger than ten thousand (10,000) square feet, the above parking requirement shall be provided and the following percentage shall be taken of the remaining net floor area: 10,001-20,000 sq. ft. – 95% of parking requirement 20,001-30,000 sq. ft. – 90% of parking requirement 30,001-40,000 sq. ft. – 85% of parking requirement 40,000 sq. ft. and up - 80% of parking requirement

Art. 501 Off-Street Parking and Loading

COMMERCIAL USES	
General Business and Retail Sales (except as otherwise provided herein)	1 space per two hundred fifty (250) square feet of net floor area up to ten thousand (10,000) square feet, the above parking requirement shall be provided and the following percentage shall be taken of the remaining net floor area: 10,001-20,000 sq. ft. – 95% of parking requirement 20,001-30,000 sq. ft. – 90% of parking requirement 30,001-40,000 sq. ft. – 85% of parking requirement 40,000 sq. ft. and up – 80% of parking requirement
Bowling Alleys	6 spaces for each lane
Restaurants (and similar establishments serving food and beverages)	1 space per each four (4) occupants at the maximum permitted occupancy allowed under building code and 1 space per employee based on the largest shift.
Drive-Through Commercial Facilities	In addition to the other parking space requirements, holding or stacking spaces for each service window. Each stacking space shall be no less than ten (10) feet wide by twenty (20) feet long.
Food Store, Supermarkets and Convenience Type Grocery Stores	1 space for each 200 sq. ft. of net building area; or use the reduction permitted under General Business and Retail Sales.
Personal Service Establishments (Barber, Beauty Shops and similar uses)	1 space per each employee plus 1 space per each station
Automotive Services (service stations, garages, automobile washing facilities and similar uses)	5 spaces plus 1 space for each 200 sq. ft. of net building area.
INDUSTRIAL USE	
Manufacturing, Processing and Wholesaling (and similar uses or establishments)	1 space per 600 sq. ft. of net floor area
Warehouse and Storage	5 spaces plus 1 space per 2,000 sq. ft. of net floor area up to 50,000 sq. ft.; then, in addition to the above requirement, 1 space per 10,000 sq. ft. above 50,000 sq. ft. or portion thereof.

SEC. 501.7 SURFACING OF PARKING LOTS

Any off-street parking area shall be paved with a sealed surface pavement and maintained to prevent dust resulting from continued use. The parking area should be arranged as efficiently as possible, be so graded and drained as to dispose of all surface water accumulated in the area, and shall be so arranged and marked as to provide for orderly and safe parking and storage of vehicles.

SEC. 501.8 OFF-STREET PARKING LOTS IN RESIDENTIAL DISTRICTS

Whenever off-street parking lots for more than five (5) vehicles are to be located within or adjacent to a residential district, the following provisions shall apply:

- A. Landscaping.** All yards shall be landscaped with grass, shrubs or evergreen ground cover and maintained in good condition the year round.
- B. Paving.** All of the lot used for parking and driveway purposes shall be paved with a sealed surface pavement and maintained in such a manner that no dust will be produced by continued use.
- C. Lighting.** The intensity of light and arrangement of reflectors shall be such as not to interfere with residential district uses.
- D. Signage.** No sign of any kind shall be erected except information signs used to guide traffic and to state the conditions and terms of the use of the lot. Only non-intermittent incandescent, fluorescent or gas lighting of signs shall be permitted.

SEC. 501.9 JOINT PARKING FACILITIES

Whenever two (2) or more uses are located together in a common building, shopping center, or other integrated building complex, the parking requirements may be complied with by providing a permanent parking facility, cooperatively established and operated, which contains the requisite number of spaces for each use. Total number of spaces provided shall not be less than the sum of the individual requirements.

SEC. 501.10 OFF-STREET LOADING

In addition to all off-street parking requirements, off-street loading requirements shall be in effect on the same premises with every building, structure, or part thereof hereafter erected, established or enlarged and occupied for manufacturing, storage, warehouse, goods display, department store, wholesale, market, hotel, laundry, dry cleaning, or other uses involving the receipt or distribution by vehicles of materials or merchandise. There shall be provided and maintained adequate space for standing, loading and unloading to avoid undue interference with public use of the street or alley.

- A. Size of Off-Street Loading Spaces.** Each loading space shall not be less than ten (10) feet in width, thirty-five (35) feet in length, and fourteen (14) feet in height. Where the off-street loading space does not abut on a street, alley or easement of access, there shall be provided an access drive of at least ten (10) feet in width leading from the street to the loading area. Where the off-street loading space faces a public street, the loading space shall be 70 feet in length.
- B. Location.** Such loading space may occupy all or any part of any required setback, but such space may not be located closer than twenty-five (25) feet to any residential district unless wholly within a completely enclosed building or unless enclosed on all sides abutting the residential district by a wall or said fence at least eight (8) feet in height.
- C. Number of Off-Street Loading Spaces Required**
 - 1. One Loading Space Required.** For every building or structure hereafter constructed in any district for nonresidential purposes, or where material or merchandise is received or distributed by vehicles, an off-street loading space shall be provided and maintained on the same lot.
 - 2. Substitution.** Parking spaces may not be substituted for a loading space or a loading space substituted for a parking space.

3. Standards.

Floor Area (sq. ft.)	Loading Spaces Required
5,000 - 25,000	1
25,000 - 40,000	2
40,000 - 100,000	3
100,000 - 160,000	4
160,000 - 240,000	5
240,000 - 320,000	6
For each additional 90,000	1 added space

SEC. 501.11 APPEALS

Appeals to parking requirements may be made as stipulated in Art. 300 Administration.

SEC. 501.12 PARKING AND STORAGE OF CERTAIN VEHICLES

Automotive vehicles or trailers of any kind or type without current license plates shall not be parked or stored on any residentially zoned property other than in complete enclosed buildings or carports.

Rev. 11-23-10
Ord. No. 2010-71

Art. 501 Off-Street Parking and Loading